

REALITZA UNA INTERPRETACIÓ LLUIRE D'AQUESTA COMPOSICIÓ. INTENTA DONAR UN NOU SENTIT A CADA UN DELS OBJECTES ENCARA QUE SIGUI IRREAL.

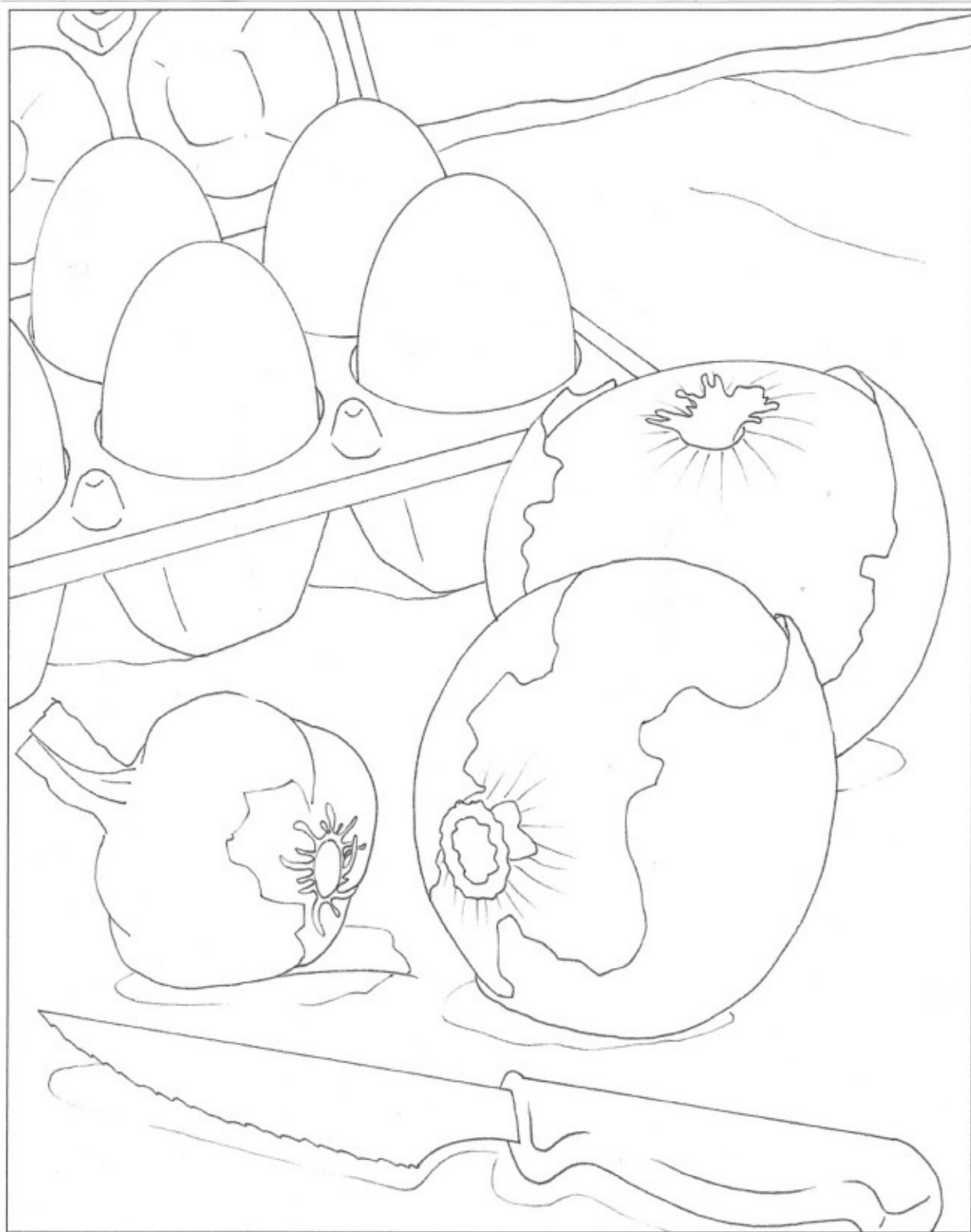

REPRODUUEIX EL MÉS GRAN POSSIBLE L'ESBÓS QUE HAGUEM TRIAT. DESPRÉS HO DEFORMES AMB LA TÈCNICA DE SUPERPOSICIÓ D'UNA TRAMA ONDULADA SEGONS UTILITCEN ELS ARTISTES VISUALS (OP ART)
REALITZAR EL DIBUIX AMB LLAPIS I DEFIR LES SUPERFÍCIES AMB RETOLADOR NEGRE.

DIBUIXAR LA RECTA MEDIATRIU DEL SEGMENT A-B.

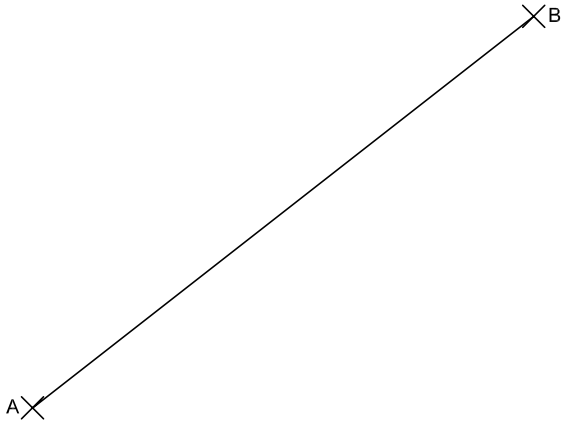

DIBUIXAR LA RECTA PERPENDICULAR AL SEGMENT A-B QUE PASSI PEL PUNT A.

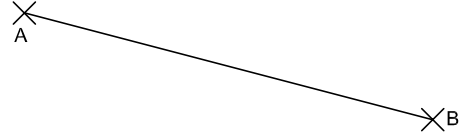

DIBUIXAR LA RECTA BISECTRIU DE LES SEMIRECTES R I S.

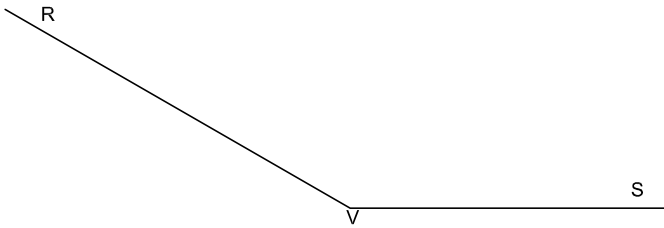

DIBUIXAR LES RECTES TRISECTRIUS DE L'ANGLE FORMAT PER R I S.



UTILITZANT EL MÈTODE DE THALES DIVIDIU EL SEGMENT A-B EN 7 PARTS IGUALS.

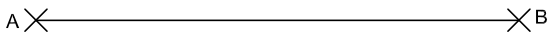

UTILITZANT EL MÈTODE DE THALES DIVIDIU EL SEGMENT A-B EN PARTS PROPORCIONALS A 2, 3, 1.

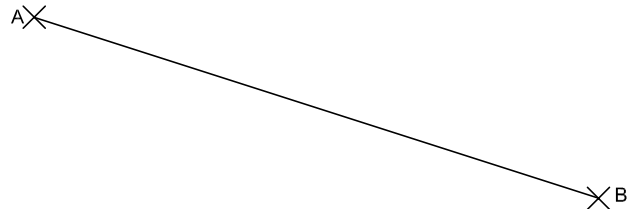

UTILITZANT EL MÈTODE DE DIVISIÓ DE LA CIRCUMFERÈNCIA EN PARTS IGUALS, DIBUIXAR L'ENNEÀGON REGULAR (9 COSTATS)
INSCRIT A LA CIRCUMFERÈNCIA DE CENTRO O I RADI 7 CM. DIVIDIU EL DIÀMETRE QUE PASSI PER LA RECTA DE PUNTS.

×

O

DIBUIXAR UN PENTÀGON REGULAR INSCRIT A LA CIRCUMFERÈNCIA

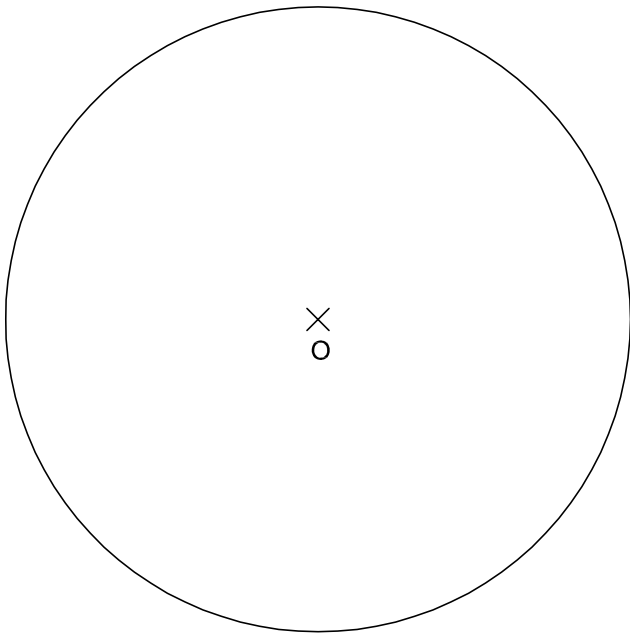

DIBUIXAR UN HEPTÀGON REGULAR INSCRIT A LA CIRCUMFERÈNCIA

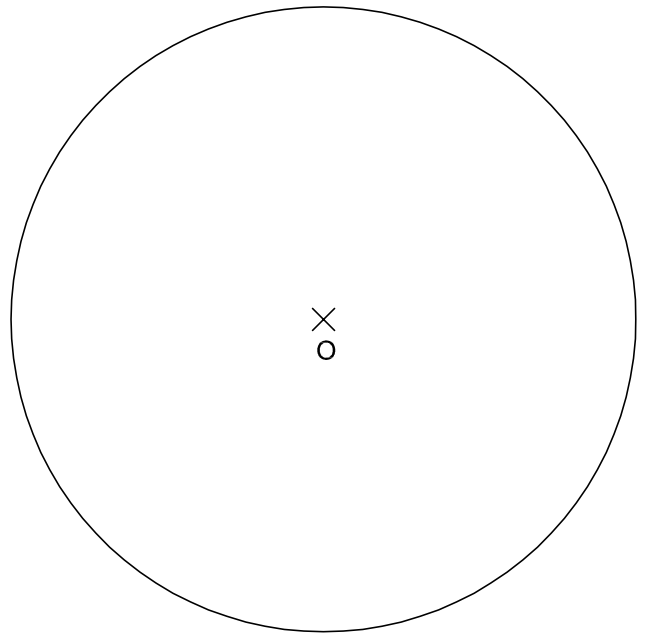

DIBUIXAR UN POLIGON ESTRELLAT DE DEU PUNTES INSCRIT A LA CIRCUMFERÈNCIA I EL DECORAU AMB ALTRES FORMES Y COLORS.

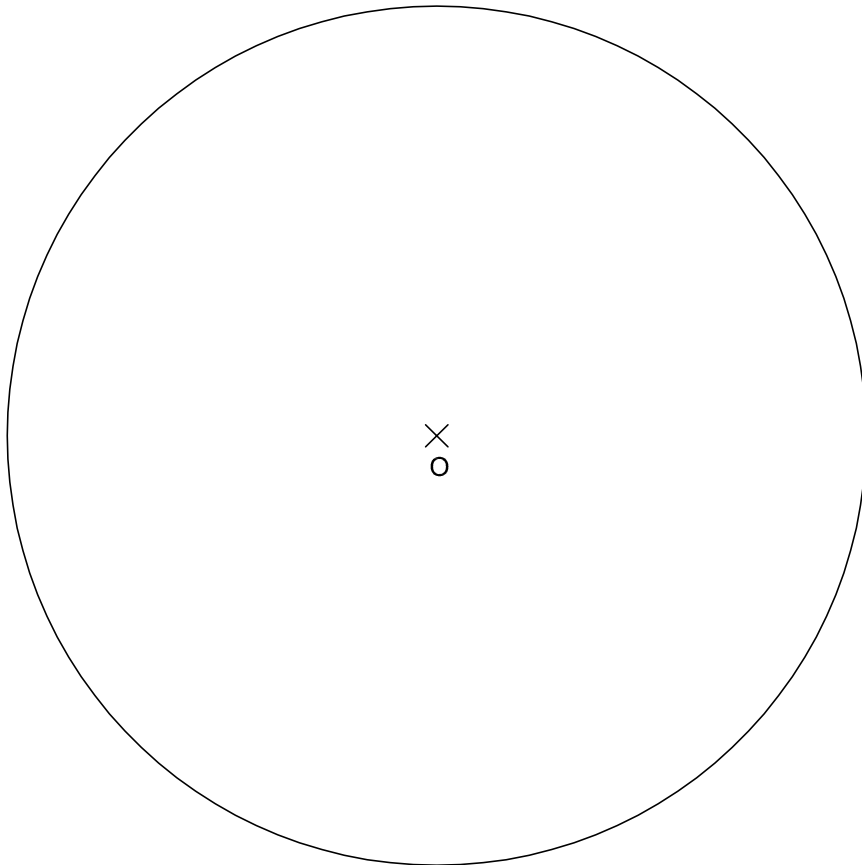

DIBUIXAR LES RECTES TANGÈNTS A LA CIRCUMFERÈNCIA DONADA EN ELS PUNTS A I B.

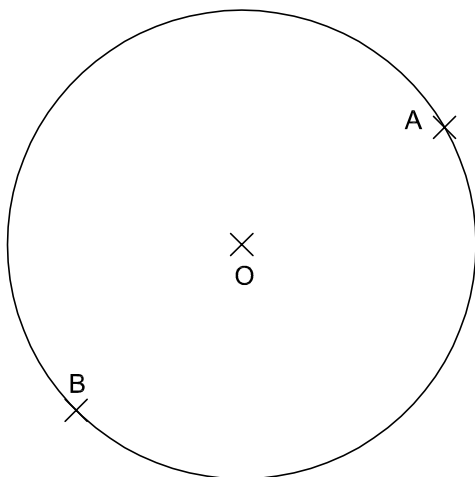

DIBUIXAR LES RECTES TANGENTS A LA CIRCUMFERÈNCIA DE CENTRE O DES DEL PUNT A. INDICANT EXACTAMENT ELS PUNTS DE TANGÈNCIA.

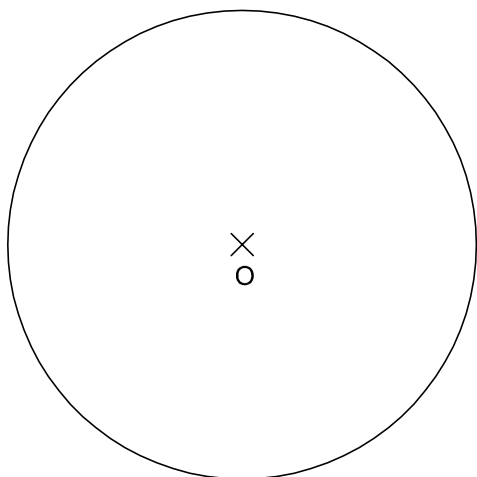

A x

DIBUIXAR LES CIRCUMFERÈNCIES DE RADI 1,5 CM TANGENTS A LA CIRCUMFERÈNCIA DONADA EN ELS PUNTS A I B.

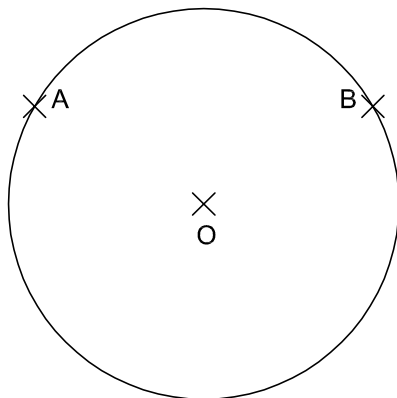

DIBUIXAR LES RECTES TANGENTS INTERIORS COMUNES A LES DUES CIRCUMFERÈNCIES DONADES.

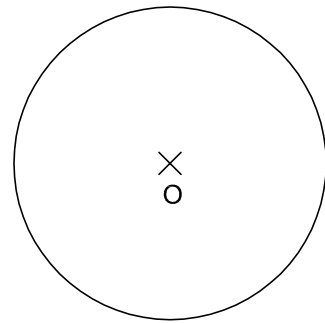
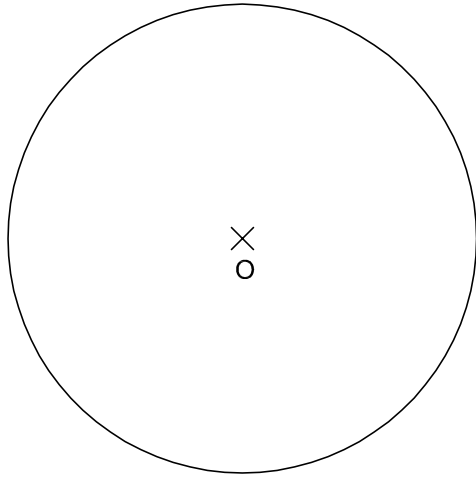

DIBUIXAR LES RECTES TANGENTS EXTERIORS COMUNES A LES DUES CIRCUMFERÈNCIES DONADES.

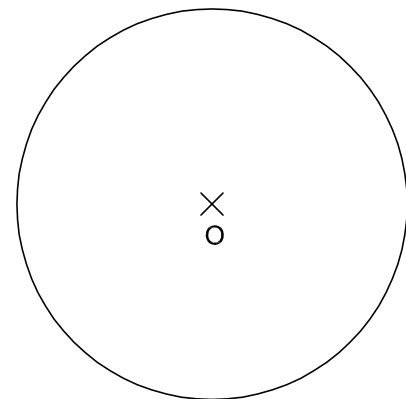
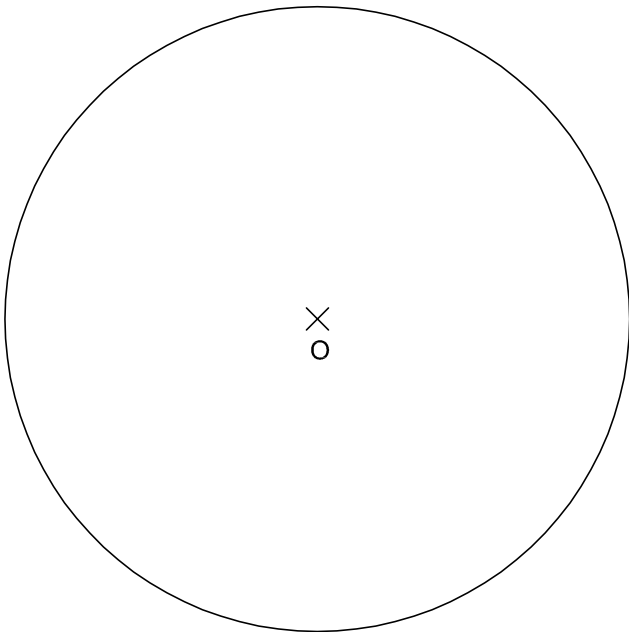

MITJANÇANT LA TÈCNICA DEL PLEGAT I APLICACIÓ DE TALLS, REALITZA UNA COMPOSICIÓ VOLUMÈTRICA.

REALITZAR UN MÍNIM DE 3 PROVES O ESBOSSOS ABANS DE LA FORMA DEFINITIVA. ANALITZAR ELS EXEMPLES PROPOSATS A CONTINUACIÓ.

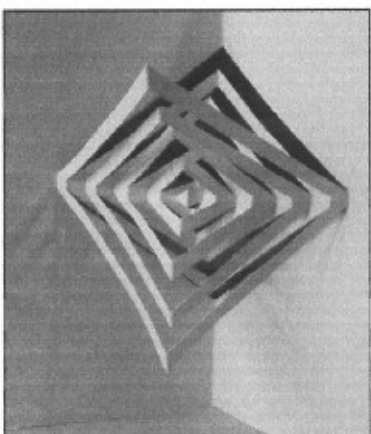
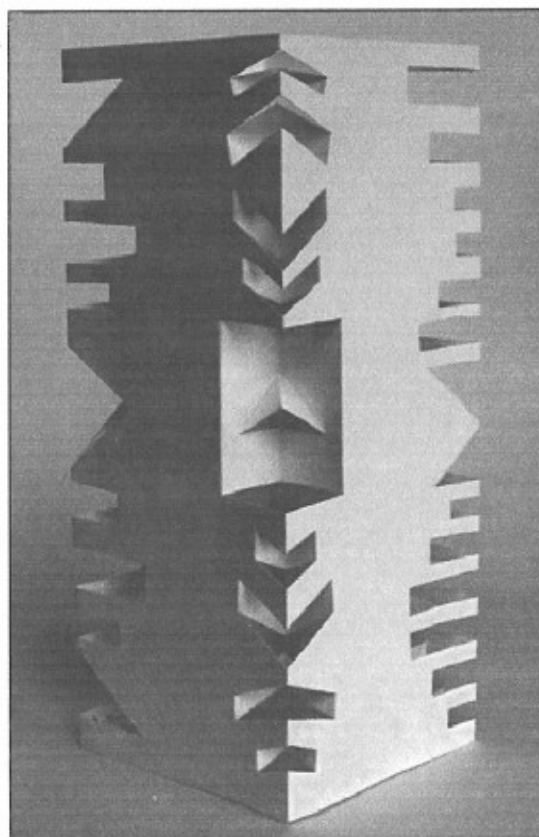
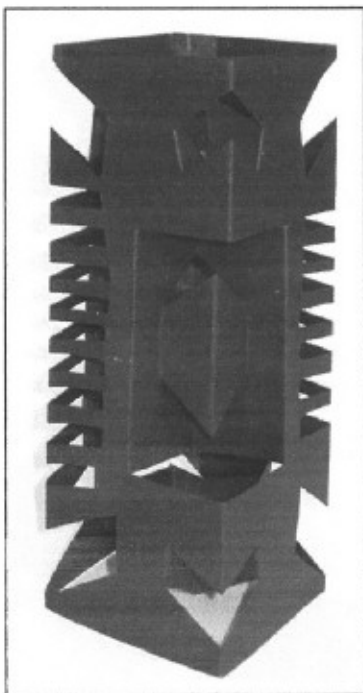
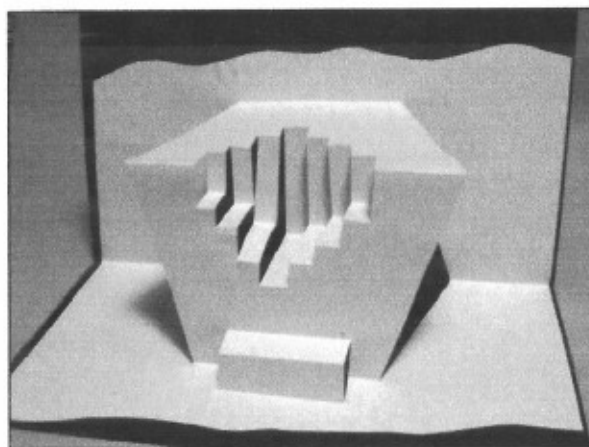
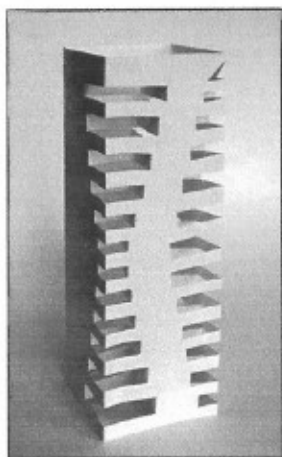
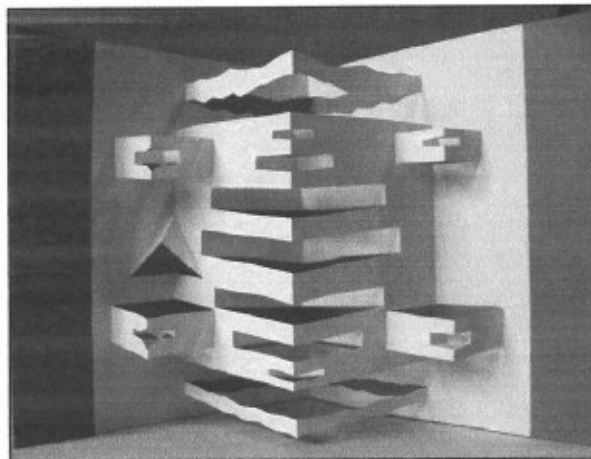
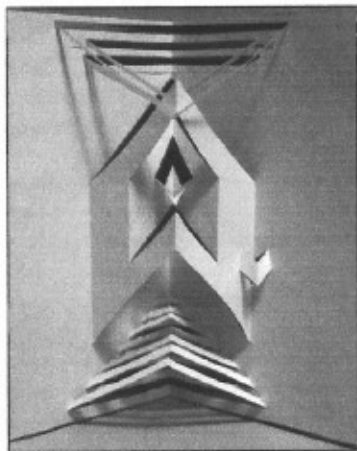

DEPARTAMENT D'ARTS PLÀSTIQUES I VISUALS. CIDE.

SOBRE LA QUADRICULA, DIBUIXAR LA PLANTA, ALÇAT I EL PERFIL QUE ES VEUE LES FIGURES SEGÜENTS.

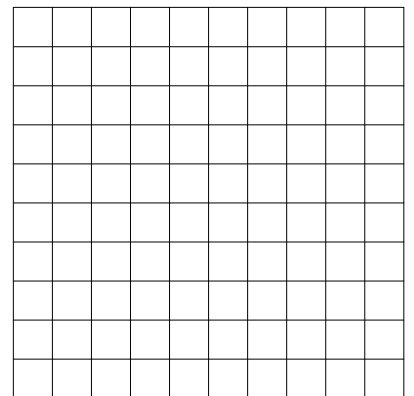
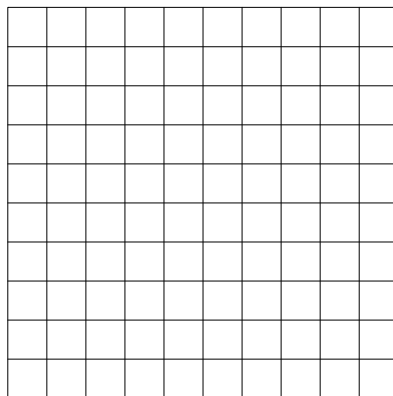
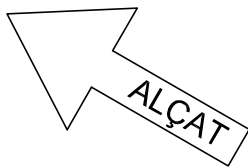
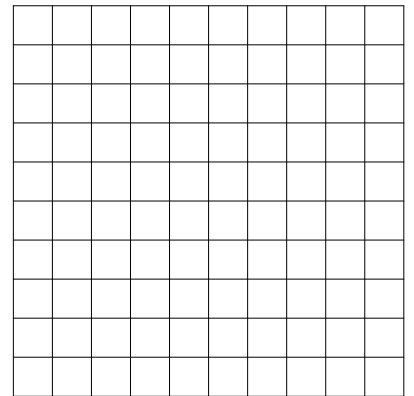
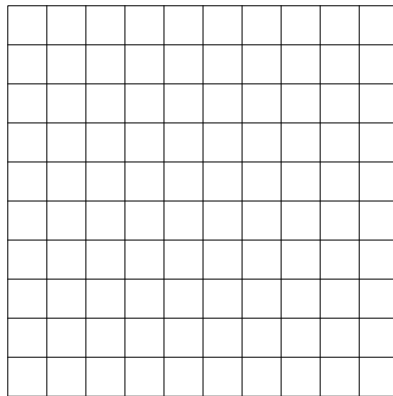
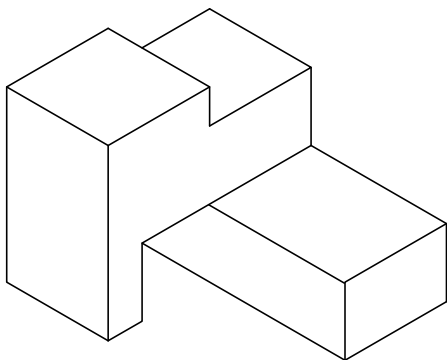
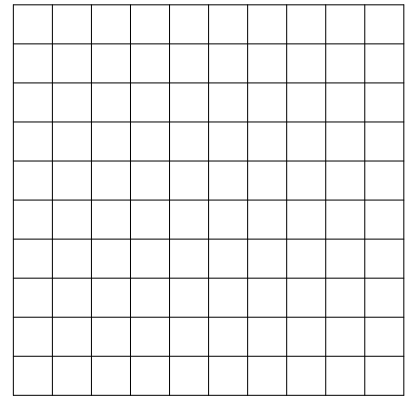
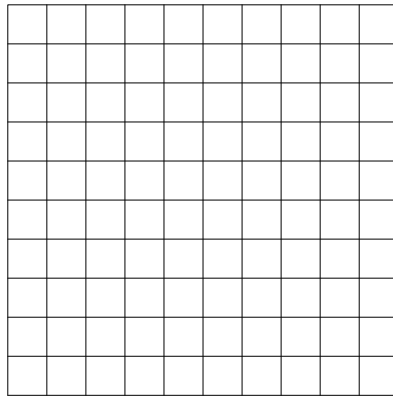
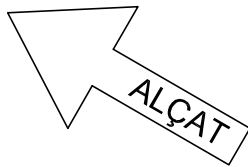
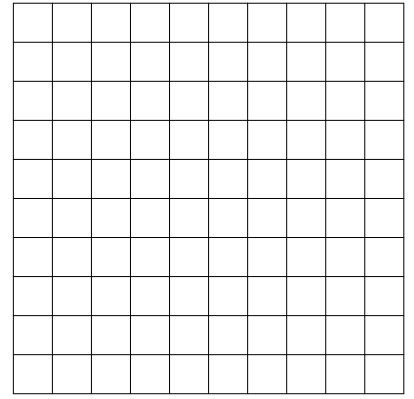
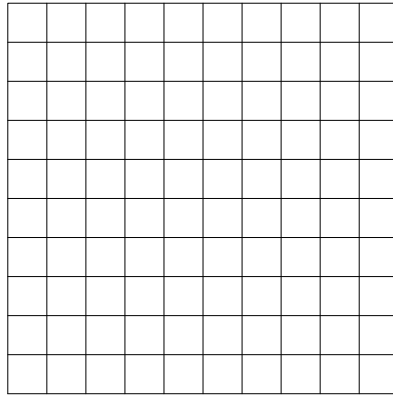
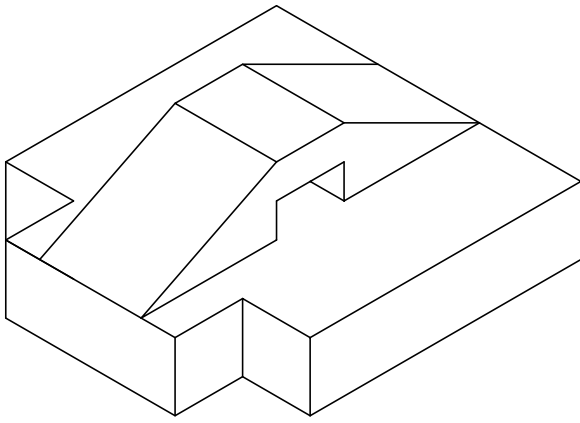

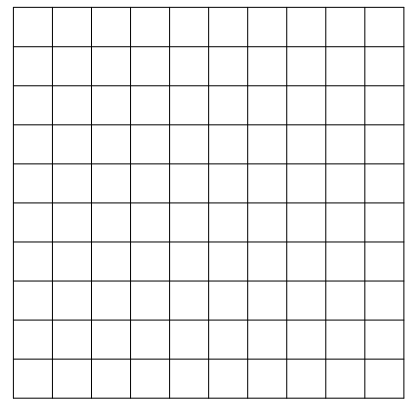
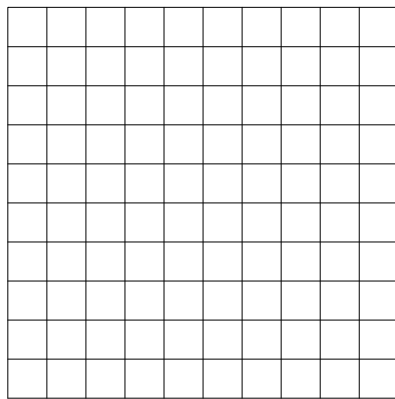
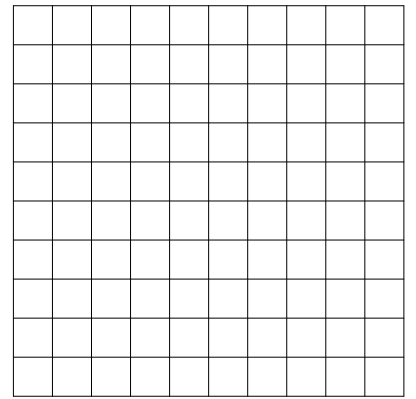
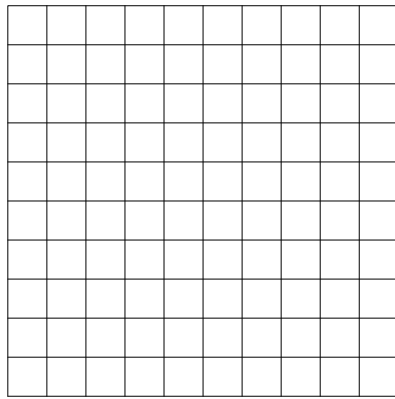
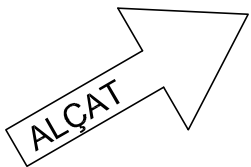
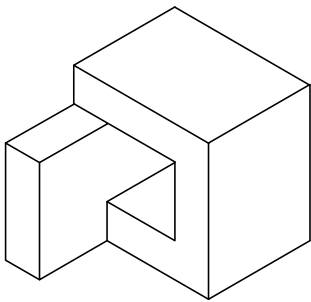
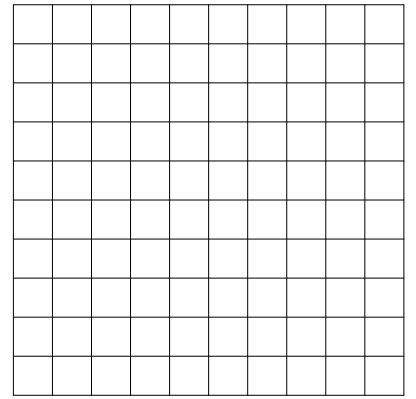
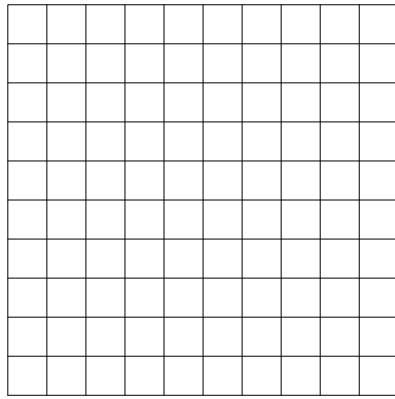
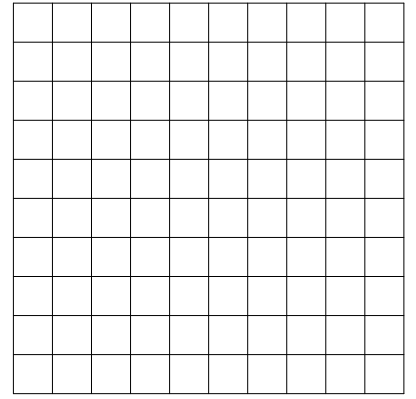
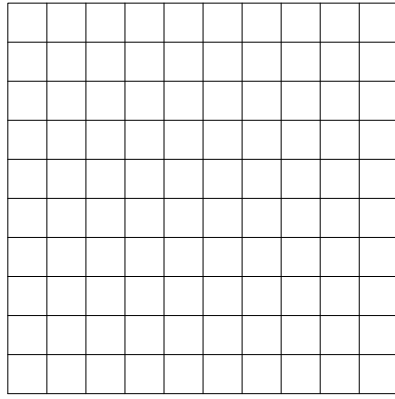
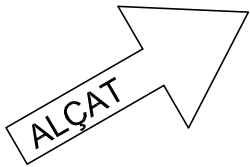
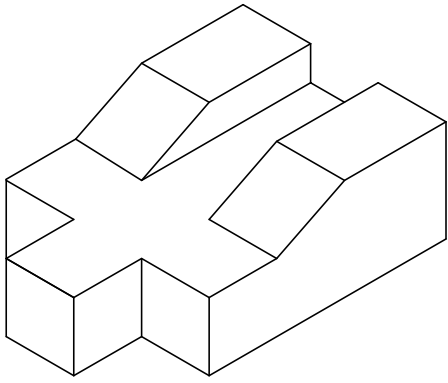

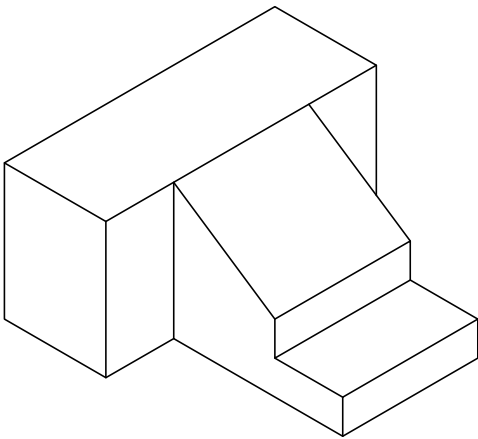
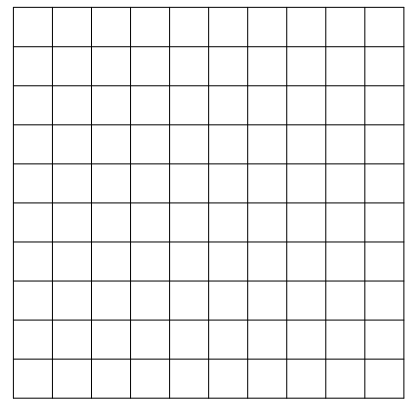
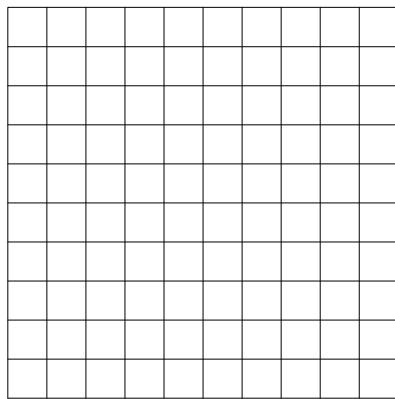
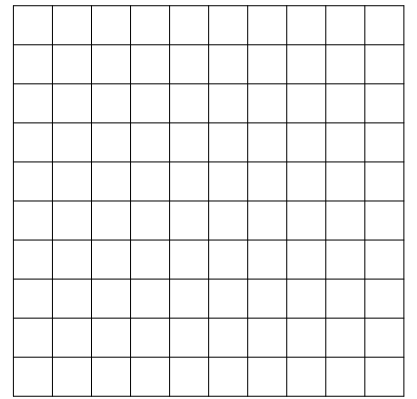
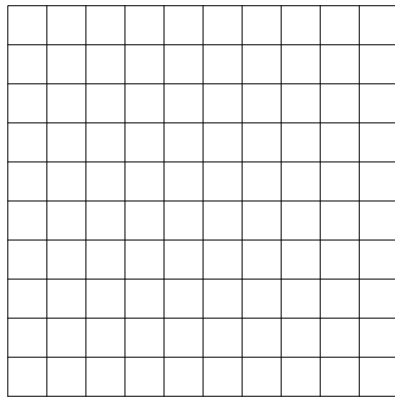
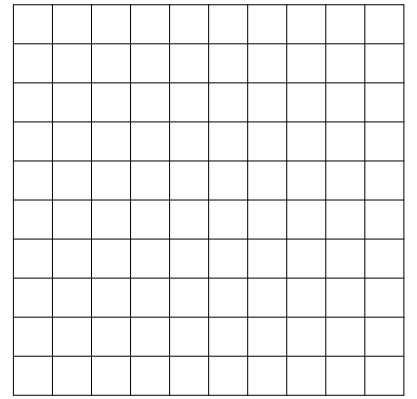
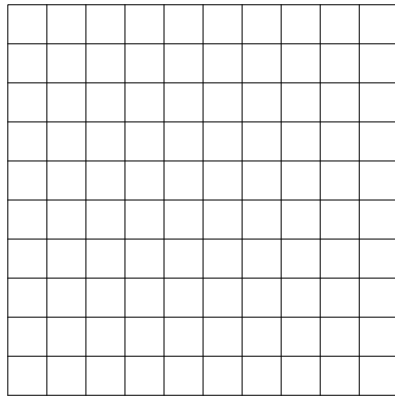
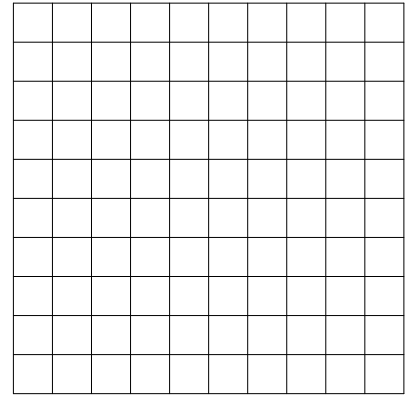
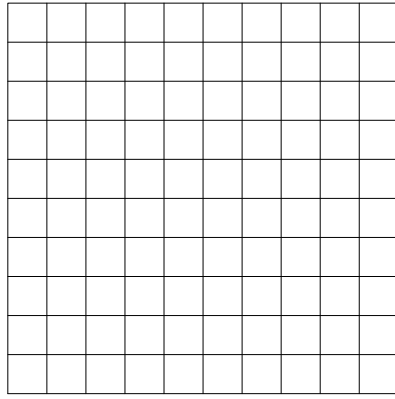
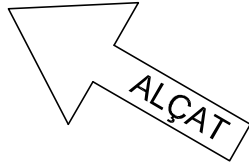
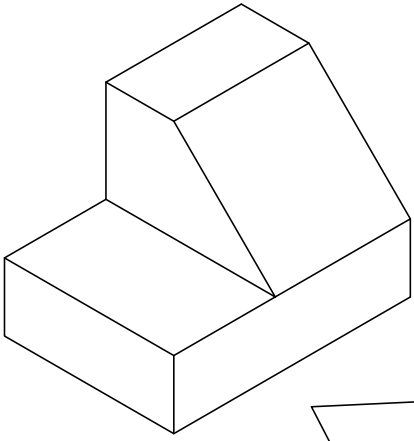

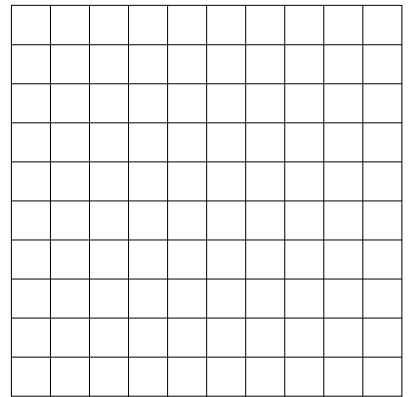
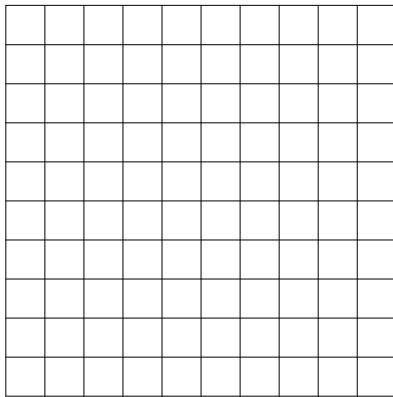
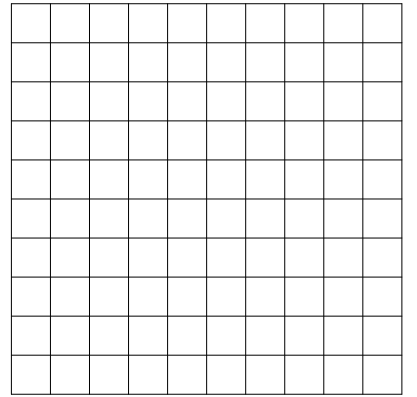
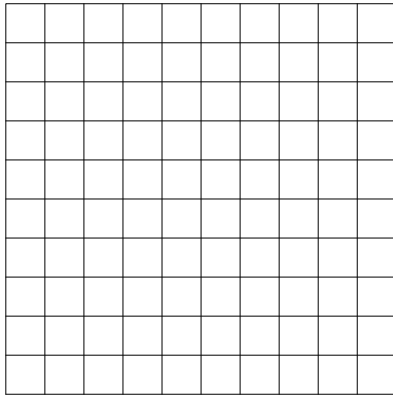
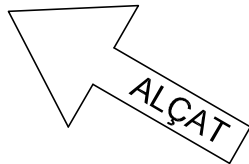
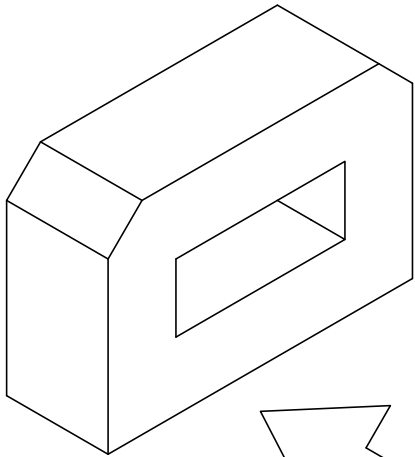
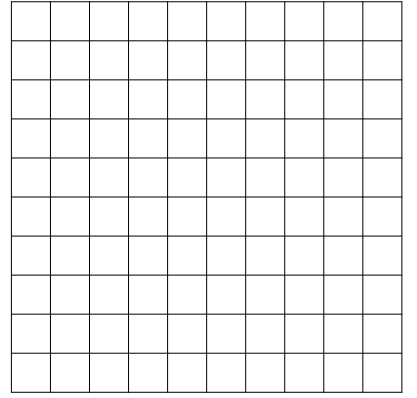
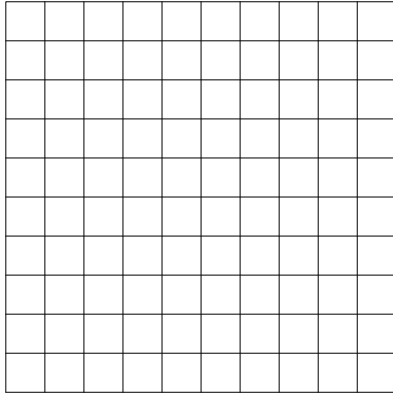
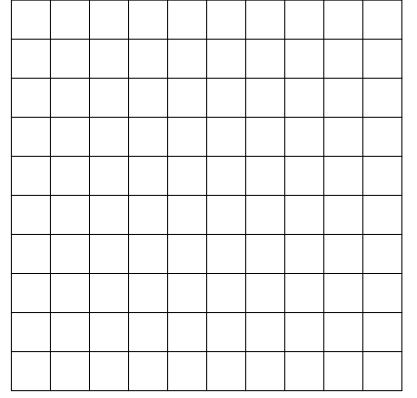
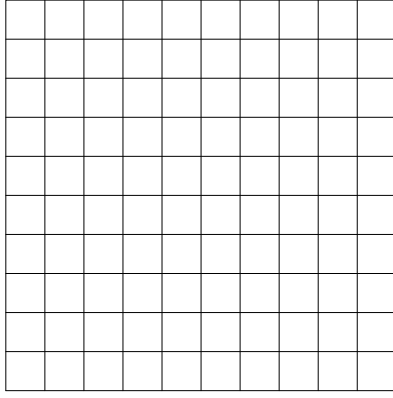
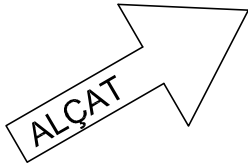
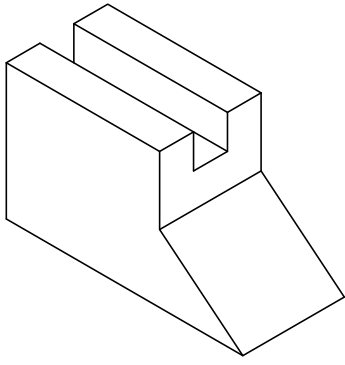

A ESCALA DOBLE, DIBUIXAR LES PERSPECTIVES AXONOMÈTRIQUES DE LES FIGURES SEGÜENTS.

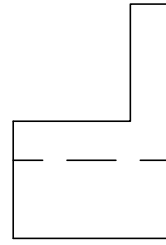
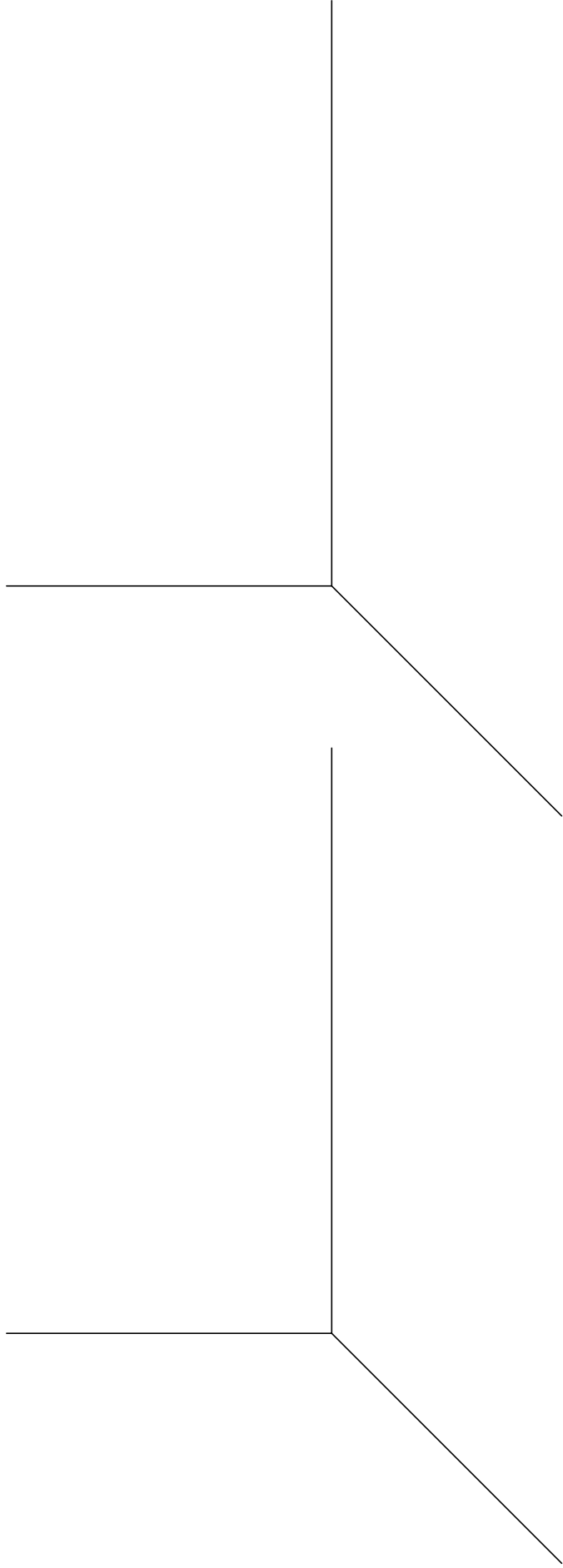

PERFIL ESQUERRE

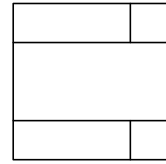

ALÇAT

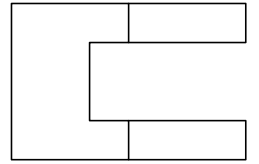

PLANTA

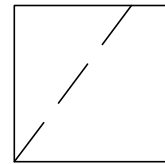

PERFIL ESQUERRE

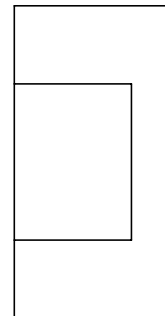

ALÇAT

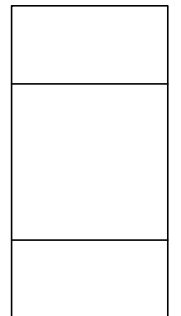

PLANTA

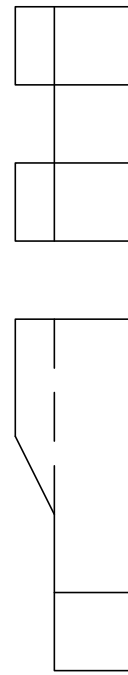
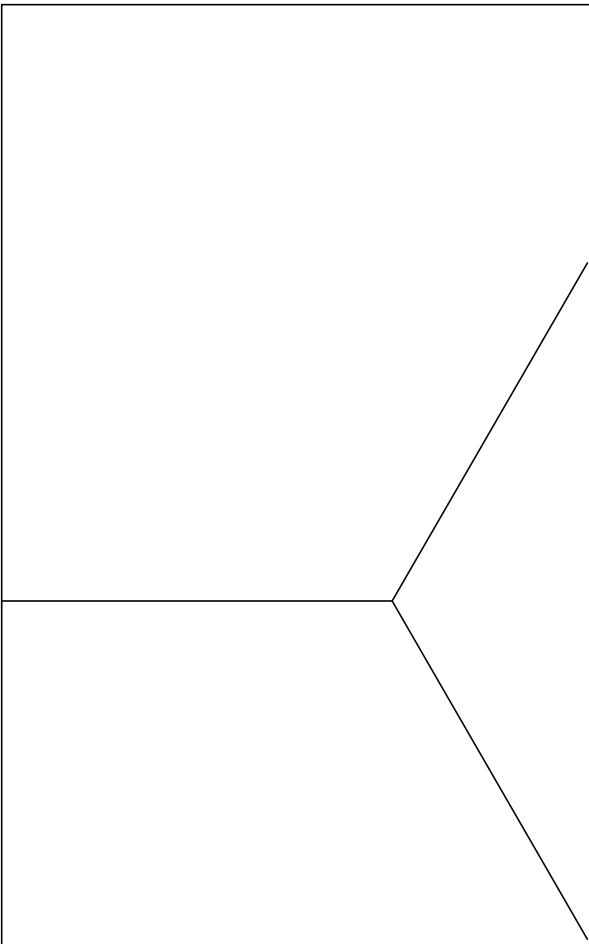

ALÇAT

PERFIL ESQUERRE

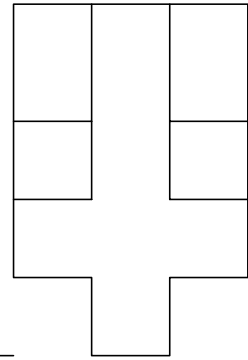

PLANTA

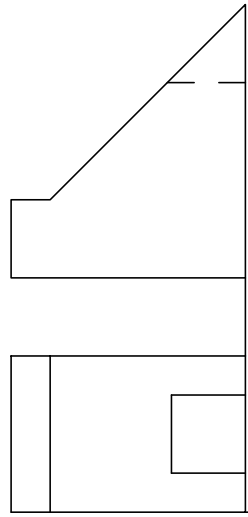
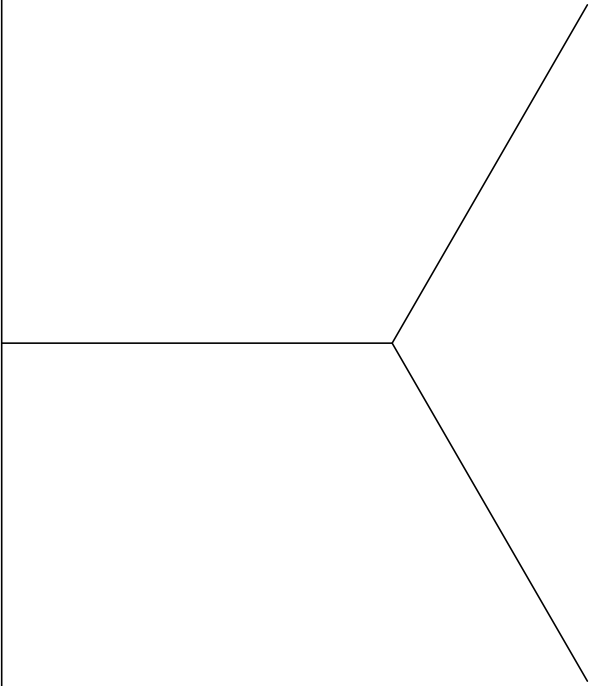

ALÇAT

PERFIL ESQUERRE

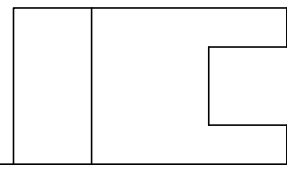

PLANTA

A PARTIR DE LA TRAMA DONADA, DISSENYAR UNA PORCIÓ DE CIUTAT, UN ENCREUAMENT DE CARRERS AMB EDIFICIS, PARCS, PERSONES, VEHICLES I MOBILIARI URBA.

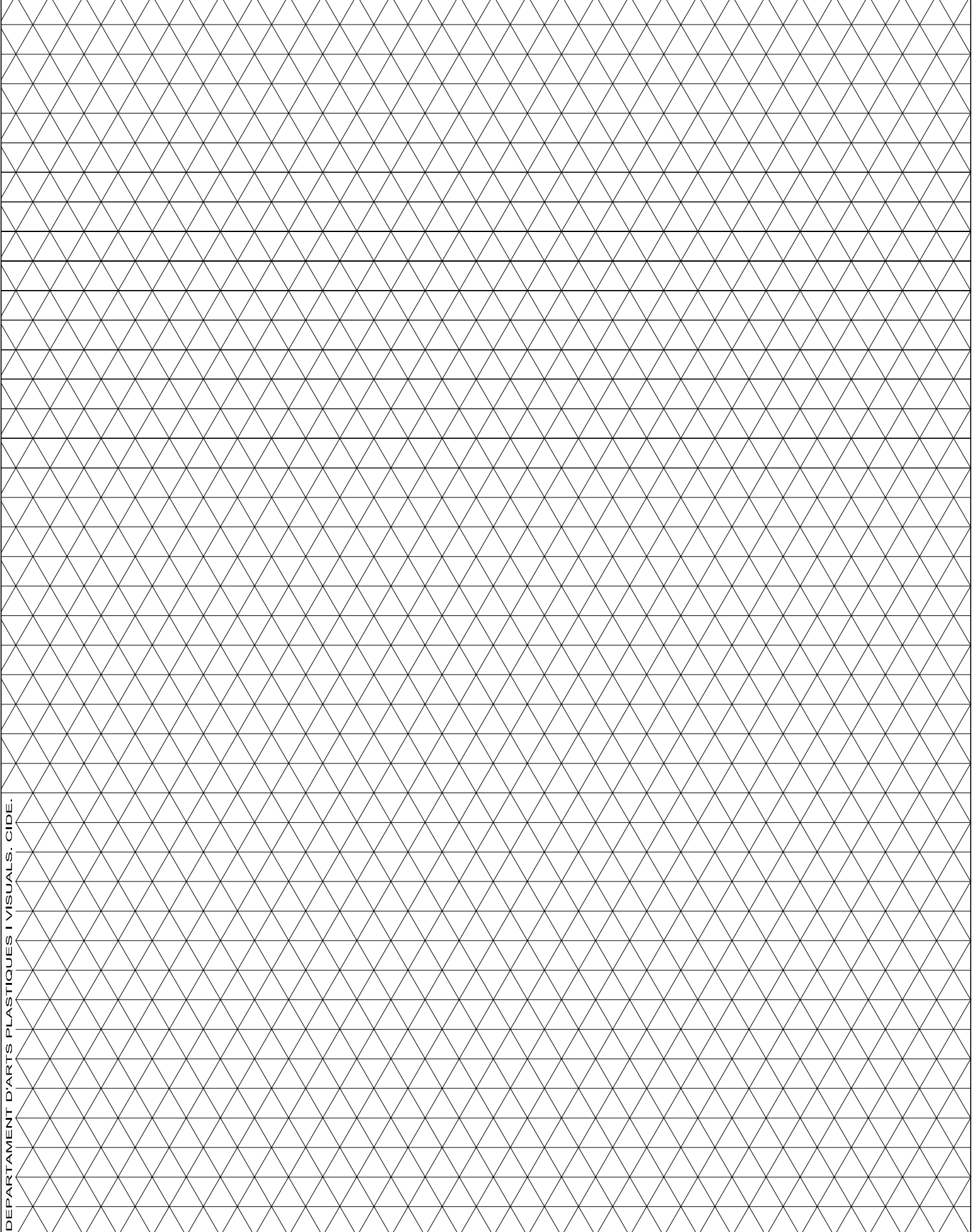

DEPARTAMENT D'ARTS PLÀSTIQUES I VISUALS. CIDE.